

MODEL 130 BRONCO

Pressure Sensitive *applying excellence* Labeler



- Servo-driven labeling machine
- Stainless steel construction
- Open-frame design
- Stainless steel raised-bed conveyor
- PLC controls 
- Swivel-mounted color touch screen HMI Control
- Speeds up to 200 cpm

Ideal for cosmetic and personal care, household chemical producers, contract packagers and the pharmaceutical industry.

This open-frame servo driven pressure sensitive labeler handles a wide range of containers and label applications at speeds up to 200 containers per minute.



A Century of Packaging Expertise

Model 130 BRONCO Pressure Sensitive Labeler

Standard Features

- Stainless steel construction
- Conveyor mounted accessories on slide mechanism for quick format change
- Open-frame design
- Stainless steel raised-bed conveyor
- PLC controls
- Swivel-mounted 6" color touch screen HMI controls
- Recipe management
- Servo-driven label dispenser
- Repeatable heavy-duty dispenser mount with digital adjustment
- Variable dispensing speed up to 1,500" (38 meters) per min
- Speeds up to 200 cpm

Size of Labels

- Length: Min: 5/8" (16mm) Max: 12" (317mm)
- Height: Min: 5/8" (16 mm) Max: 7" (178 mm)
- Roll Size: Max: 14" (355mm) with 3" (76mm) core diameter
- Optional larger roll size available

Container

- Diameter: Min: 5/8" (16mm) Max: 7" (178mm)
- Height: Min: 1" (25mm) Max: 14" (356mm)

Air & Electrical Requirements

- Air Supply: 80 psi, 2scfm
- Power Supply: 208VAC, 3 phase, 60 Hz

Overall Measurements

- Length: Base Labeler 126" (320cm)
- Width: Single dispenser - approx. 60" (152 cm)
Two dispensers - approx 70" (178 cm)
- Height: 83" (211 cm)

Available Options

- Front & back, 3, 4 or 5 panel and wrap-around labeling
- Clear label capability
- Single or dual feedscrew aligner
- Chain aligner
- Servo-driven overhead belt container stabilizer
- Dual unwind motorized label feeding system
- Label coding (hot stamping, laser, thermo transfer)
- Inspection and reject systems

Authorized NJM Packaging Sales Representative

Technical Specifications

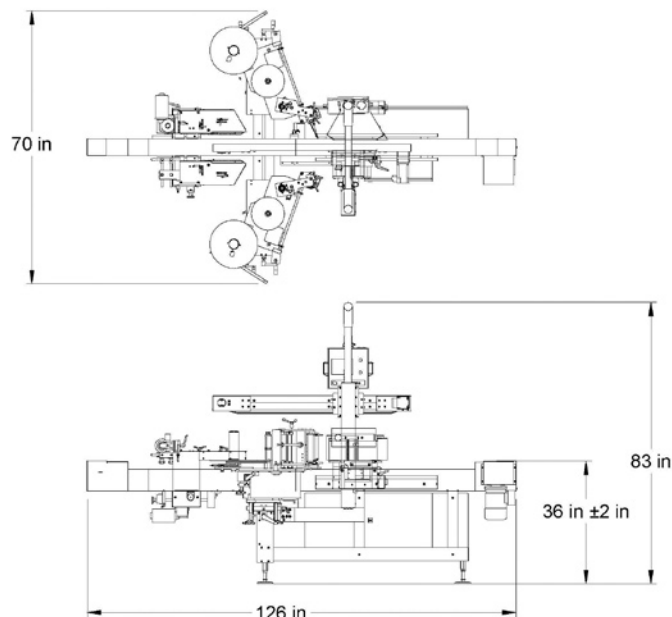

Floor Plan

Dimensions shown are for basic machines and may vary depending on options. In view of our policy of continuing research and product improvement, actual specifications may vary from those shown. Please consult with an NJM Packaging representative regarding your specific requirements.

All NJM Packaging equipment is covered by a one year warranty on parts. A comprehensive nationwide service, parts, and sales support program is available for the life of your equipment. A customized Preventative Maintenance Program for this equipment is also available.

Contact our Customer Service Department at (603) 448-3940 for more information.

This equipment can be purchased separately or as part of a fully integrated packaging line. Contact your sales representative for full details on other packaging equipment and complete turnkey line integration services.

Protected by one or more U.S. and foreign patents.



A Century of Packaging Expertise

USA 56 Etna Road
Lebanon, NH 03766 USA
1-800-432-2990

CANADA 5600 Kieran, Montreal QC
Canada H4S 2B5
1-800-811-6990
www.njmpackaging.com

Copyright © 2011 NJM Packaging

