

MODEL
324 ROTACAP

Rotary Capper

fascinating tops

This high speed rotary capping machine handles a wide range of containers and caps at speeds up to 350 containers per minute.



- Heavy duty construction
- PLC controls
- Horizontal cap transfer disc
- Raised bed conveyor
- Magnetic clutch with calibrated torque adjustment
- Positive container handling

Automated with
**Rockwell
Automation**
© Allen-Bradley - Rockwell Software



A Century of Packaging Expertise

Model 324 ROTACAP Rotary Capper

Technical Specifications

Standard Features

- Stainless steel cabinet
- Pick and Place device with quick release mechanism
- Gripper heads with magnetic clutch
- Calibrated torque adjustments
- Hardened steel control cam for head piston
- Rockwell PLC control
- Container anti-rotating device
- Safety device for jammed containers
- Prime and back up sensors
- Raised bed central conveyor section
- Fully enclosed protection guard

Containers

- Diameter Min. 30 mm, Max. 114 mm
- Height Min. 57 mm, Max. 210 mm

Cap Range

- Various screw caps for the pharmaceutical, health care and food industry, for type 400 from 24 to 70 mm

Air & Electrical Requirements

- Air supply: 90PSIG, 23SCFM
- Power supply: 208VAC, 3 phase, 60Hz, 17A

Weight

- Approx. 1400 KG

Approximate Output

- 3 heads 80/min. • 4 heads 120/min. • 6 heads 200/min.
- 8 heads 250/min. • 10 heads 300/min. • 12 head 350/min.

Available Options

- Cap feeder: elevator / orienter - centrifugal feeder
- Cap inspection system
- Separate gear motor for spindle adjustment

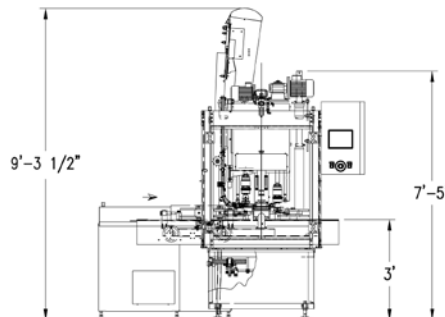
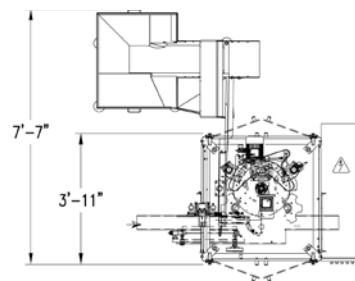

Floor Plan

Dimensions shown are for basic machines and may vary depending on options. In view of our policy of continuing research and product improvement, actual specifications may vary from those shown. Please consult with an NJM Packaging representative regarding your specific requirements.

All NJM Packaging equipment is covered by a one year warranty on parts. A comprehensive nationwide service, parts, and sales support program is available for the life of your equipment. A customized Preventative Maintenance Program for this equipment is also available.

Contact our Customer Service Department at (603) 448-3940 for more information.

This equipment can be purchased separately or as part of a fully integrated packaging line. Contact your sales representative for full details on other packaging equipment and complete turnkey line integration services.

Protected by one or more U.S. and foreign patents.

Authorized NJM Packaging Sales Representative



A Century of Packaging Expertise

USA 56 Etna Road
Lebanon, NH 03766 USA
1-800-432-2990

CANADA 5600 Kieran, Montreal QC
Canada H4S 2B5
1-800-811-6990
www.njmpackaging.com

Copyright © 2011 NJM Packaging

