

MODEL 126 TROTTER

Pressure Sensitive *applying excellence* Labeler



- Servo-driven label dispenser
- Stainless steel open frame design
- Stainless steel raised-bed conveyor
- PLC controls 
- Label registration sensor
- Rewind spindle
- Touch screen HMI controls
- Speeds up to 120 cpm

Ideal for cosmetic and personal care, household chemical producers, contract packagers and the pharmaceutical industry.

This servo motor driven, pressure sensitive labeler handles a wide range of containers and label applications at speeds up to 120 containers per minute.



A Century of Packaging Expertise

Model 126 TROTTER Pressure Sensitive Labeler

Technical Specifications

Standard Features

- Conveyor mounted accessories on slide mechanism for quick format change
- Open-frame design
- Stainless steel raised-bed conveyor
- PLC controls
- 6" touch screen HMI control
- Servo-driven label dispenser
- Repeatable heavy-duty dispenser mount with digital adjustment
- Speeds up to 120 cpm

Size of Labels

- Length: Min: 5/8" (16 mm) Max: 14" (355 mm)
- Height: Min: 5/8" (16 mm) Max: 7" (178 mm)
- Roll Size: Max: 14" (355 mm) with 3" (76 mm) core diameter

Container

- Diameter: Min: 5/8" (16 mm) Max: 7" (178 mm)
- Height: Min: 1" (25 mm) Max: 14" (356 mm)

Air & Electrical Requirements

- Air Supply: 80 psi, 0.6 scfm
- Power Supply: 120 VAC, 1 phase, 60 Hz

Overall Measurements

- Length: Base Labeler 126" (320 cm)
- Width: Single dispenser – approx. 65" (165 cm)
Two dispensers – approx. 86" (219 cm)
- Height: 65" (165 cm)

Available Options

- Front & back, 3, 4 or 5 panel and wrap-around labeling
- Color touch screen HMI control
- Chain aligner
- Synchronized overhead belt container stabilizer
- Label coding (hot stamping, thermo transfer)
- Inspection and reject systems

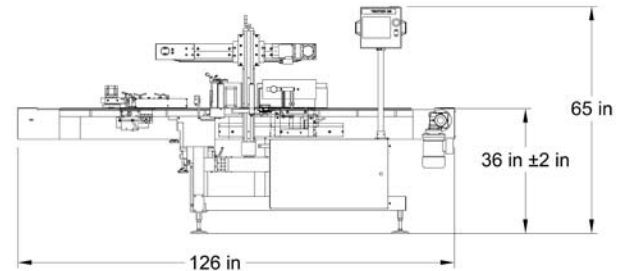
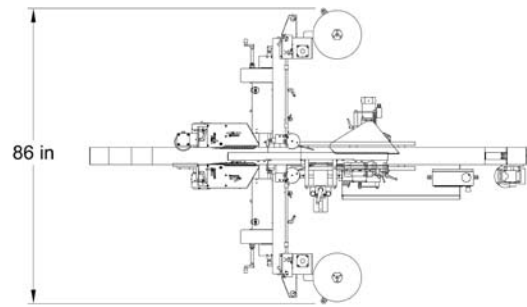

Floor Plan

Dimensions shown are for basic machines and may vary depending on options. In view of our policy of continuing research and product improvement, actual specifications may vary from those shown. Please consult with an NJM Packaging representative regarding your specific requirements.

All NJM Packaging equipment is covered by a one year warranty on parts. A comprehensive nationwide service, parts, and sales support program is available for the life of your equipment. A customized Preventative Maintenance Program for this equipment is also available.

Contact our Customer Service Department at (603) 448-3940 for more information.

This equipment can be purchased separately or as part of a fully integrated packaging line. Contact your sales representative for full details on other packaging equipment and complete turnkey line integration services.

Protected by one or more U.S. and foreign patents.

Authorized NJM Packaging Sales Representative



A Century of Packaging Expertise

USA 56 Etna Road
Lebanon, NH 03766 USA
1-800-432-2990

CANADA 5600 Kieran, Montreal QC
Canada H4S 2B5
1-800-811-6990
www.njmpackaging.com

Copyright © 2011 NJM Packaging

